

**PROPELLER (McCAULEY) - DESCRIPTION AND OPERATION****1. General**

- A. Airplanes 20800189 and On, 208B0218 and On, and airplanes that have incorporated CAB 90-20, are equipped with a McCauley Model 3GFR34C703/106GA-0 three-bladed, constant-speed, full-feathering, reversible, governor-regulated propeller.

**2. Description and Operation**

- A. A propeller governor setting is established by a propeller control lever located on the cockpit control quadrant through linkage to engine compartment. This governor pilot valve setting establishes propeller speed by balancing governor-boosted oil pressure/flow against a propeller hub servo piston with the action of return springs in the hub and centrifugal counterweights on blade shanks acting to drive servo piston in opposite direction. Since the servo piston is linked to the blades, its position thus governs their setting or blade angle and hence determines propeller speed. Increasing oil pressure against the piston drives the blades toward low pitch (high RPM) and into reverse while the return springs and counterweights, acting against the piston, drives the blades toward high pitch (low RPM) and into feather. Source of propeller system oil is engine pressure lubrication system boosted to a higher pressure by the propeller governor gear pump. Refer to Figure 1.

**NOTE:** For information and procedures not contained in this Chapter, refer to the McCauley MPC700 Propeller Overhaul Manual, MPC-26 McCauley Owner/Operator Information Manual, and McCauley Technical Report No. 722. (refer to List of Vendor Publications)

Figure 1 : Sheet 1 : McCauley Propeller Assembly Cutaway

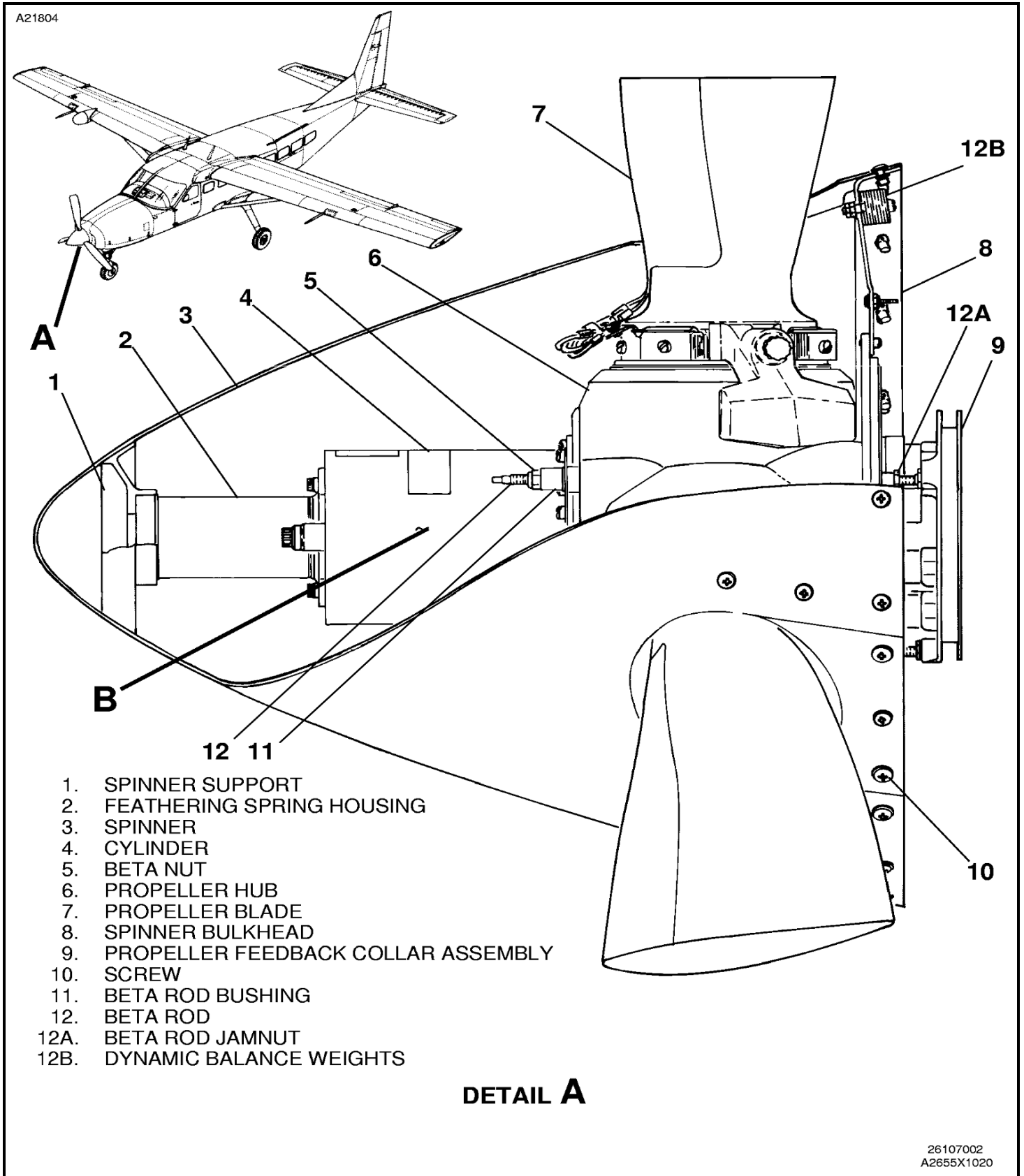
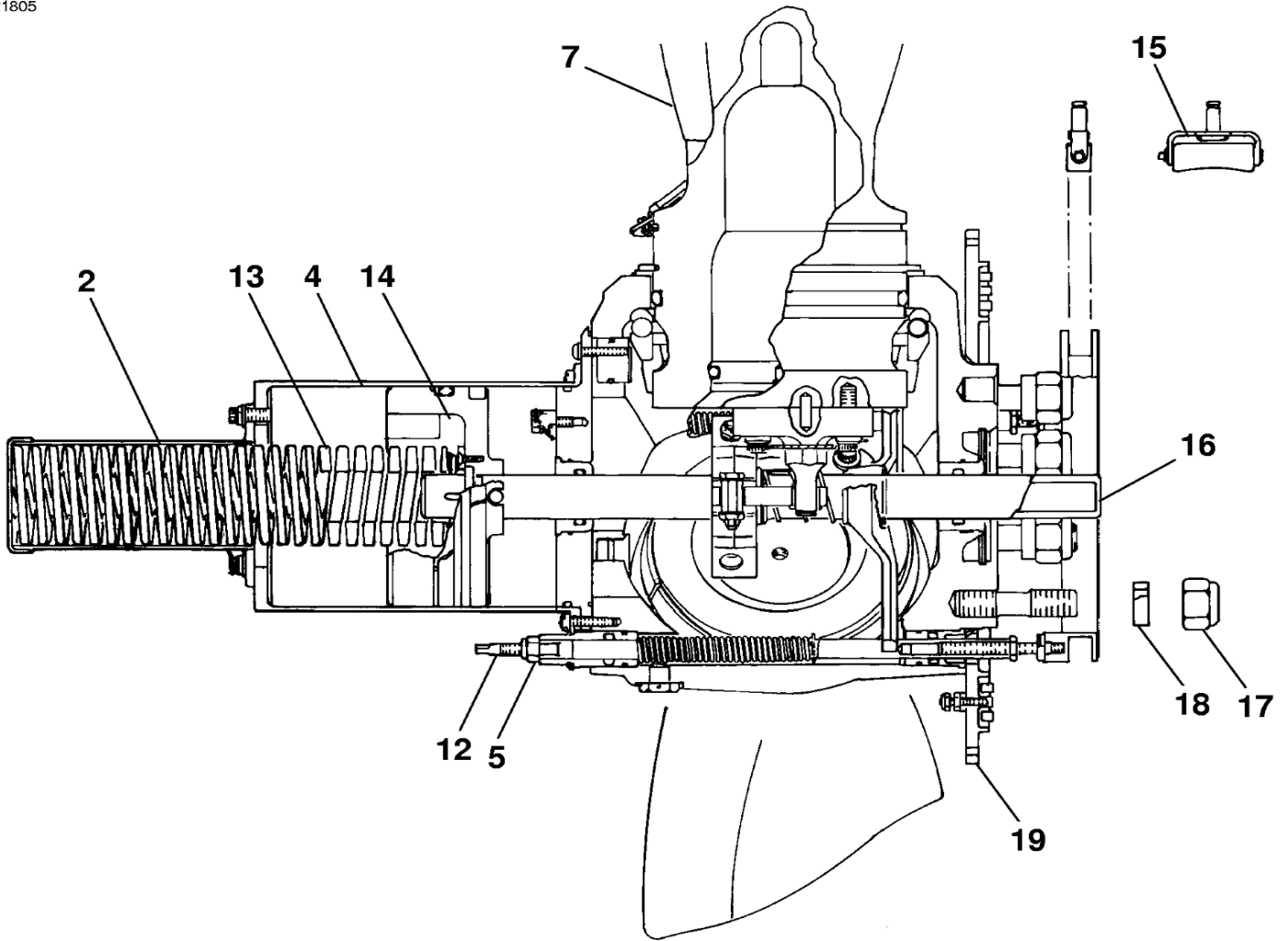

Figure 1 : Sheet 2 : McCauley Propeller Assembly Cutaway

A21805



### DETAIL B

- 2. FEATHERING SPRING HOUSING
- 4. CYLINDER
- 5. BETA NUT
- 7. PROPELLER BLADE
- 12. BETA ROD
- 13. FEATHERING SPRING
- 14. PISTON
- 15. BEARING BLOCK
- 16. PISTON ROD
- 17. NUT
- 18. SPACER
- 19. ANTI-ICE SLIP RING ASSEMBLY

2655X1021